

# Low Pressure Single Stage Regulators

## LV2302 Series

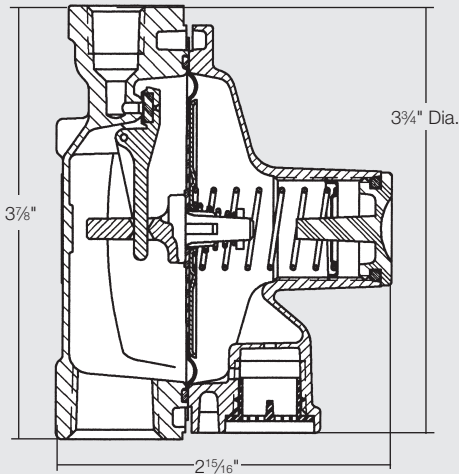

### Application

A compact, sturdy regulator incorporating many of the quality features found in larger domestic regulators. Ideal for outdoor LP-Gas grills. The regulator reduces cylinder pressure down to burner pressure, normally 11" w.c. It is intended for use on small portable appliances that use 100,000 BTU's/hr. or less. It may not be used on fixed pipe systems per NFPA 58, 1995 edition.

### Features

- Compact size with large capacity rating.
- Equipped with integral relief valve.
- Unique bonnet vent profile minimizes vent freeze over when properly installed.
- Built in pressure tap has plugged 1/8" F.NPT outlet.
- Large diaphragm provides better regulation and lower lock-up.
- Classic gold finish.

### Materials

Body . . . . . Die Cast Zinc  
 Bonnet . . . . . Die Cast Zinc  
 Spring . . . . . Steel  
 Valve Seat Disc . . . . . Resilient Rubber  
 Diaphragm . . . . . Integrated Fabric and Synthetic Rubber

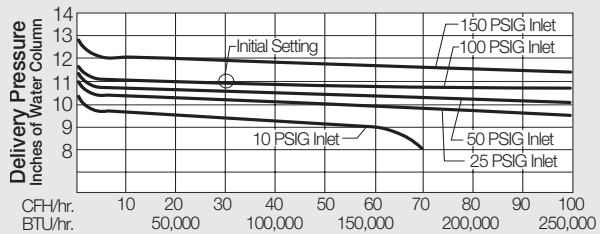

### Ordering Information

Part Number	Inlet Connection	Outlet Connection	Orifice Size	Factory Delivery Pressure	Adjustment Range	Bonnet Vent Position	Vapor Capacity BTU/hr. Propane*
LV2302A2	1/4" F. NPT	3/8" F. NPT	No. 49 Drill	11" w.c. at 100 PSIG Inlet	9" - 13" w.c.	Over Outlet	150,000
LV2302P	M. POL						

\* Maximum flow based on 10 PSIG inlet and 9" w.c. delivery pressure.